



**SPIRAL BEVEL GEARBOXES
RANGE "POWERGEAR"**

**SPARES LIST &
MAINTENANCE
INSTRUCTIONS**

Manual: MM-SBG(PG)-E-03

SUPPLIED BY: POWER JACKS LIMITED

SPIRAL BEVEL GEARBOXES RANGE “POWERGEAR”

CONTENTS

1. UNIT DETAILS	2
2. GENERAL NOTES ON SAFETY	2
3. MANUFACTURER’S DESIGNATED USE.....	3
4. TRANSPORTATION AND STORAGE	3
5. MODIFICATIONS AND ALTERATIONS.....	3
6. INSTALLATION AND ASSEMBLY.....	3
7. GENERAL ARRANGEMENT & PARTS LIST.....	4
7.1 GENERAL ARRANGEMENT.....	4
7.2 PARTS LIST	4
8. OPERATION	5
9. INITIAL OPERATION	5
10. INSPECTION AND MAINTENANCE	5
11. WARRANTY INFORMATION	7
11.1 LIMITATION OF RESPONSIBILITY	7
11.2 WARRANTY	7

1. Unit Details



Serial Number	
Model Number	
Power Jacks Sales Order No	

2. General Notes on Safety

All work involved in or involving transportation, storage, installation/assembly, initial operation, maintenance and repair must be performed by trained, qualified persons in strict compliance with

- the notes in these instructions
- the rating plate on the POWERGEAR gearbox
- the plant-specific regulations and requirements
- all regional and national rules and regulations for safety and accident prevention.

Severe damage to property and physical injury can result from

- use other than the manufacturer's designated use
- incorrect installation or operation
 - unauthorized removal of the requisite protective guards.

SPIRAL BEVEL GEARBOXES RANGE “POWERGEAR”

3. Manufacturer’s Designated Use

POWERGEAR gearboxes are components for installation in machinery and plant and are designed exclusively for the deflection and multiplication of torques within a speed range up to 6000 rpm. They are compliant with machinery directives (EN 292) and EMC directives, where applicable. Use other than or over and above that described above is contrary to the manufacturer's designated use. The manufacturer refuses to accept liability for damage or injury resulting from such other use. The user is the sole bearer of risk. POWERGEAR gearboxes can be used in many different applications so responsibility for a specific application passes to the user as of when usage commences.

4. Transportation and Storage

Damage discovered after delivery must be reported forthwith to the freight forwarder and adequate steps to prevent initial operation must be adopted, if applicable. Use handling gear of adequate load-bearing strength (rope slings, for example), if necessary. Store gearboxes in dry, dust-free, low vibration environments (bearings prone to lay-up damage) at temperatures in the range from -25 to +50°C.

5. Modifications and Alterations

Attempt no design- or safety-related modifications to POWERGEAR gearboxes without the prior, written consent of the manufacturer. Unauthorized alteration of any nature whatsoever voids the manufacturer's guarantee and warranty and excludes all liability on the part of the manufacturer.

6. Installation and Assembly

When installing or assembling, make sure that

- the support on which the gearbox rests is level, adequately damped to prevent vibration, and torsionally rigid
- the input and output drive elements (belt pulleys, couplings, universal shafts, etc.)

- are balanced
- are always installed and removed with the aid of suitable equipment
- are secured axially, even if shrink-fitted
- clamping elements, if used, must be of suitable design and tightened to specified torque
- are fitted with guards to prevent accidental contact
- belts, if fitted, are tensioned correctly in compliance with manufacturer’s specifications, and shearing forces do not exceed the limits permissible for the gears

- alignment is correct in direct-drive layouts in compliance with manufacturer’s specification
- the drive assembly is free of strain in layouts with combination flange/insertion connections
- operation is smooth and free of strain.

SPIRAL BEVEL GEARBOXES RANGE "POWERGEAR"

7. General Arrangement & Parts List

7.1 General Arrangement

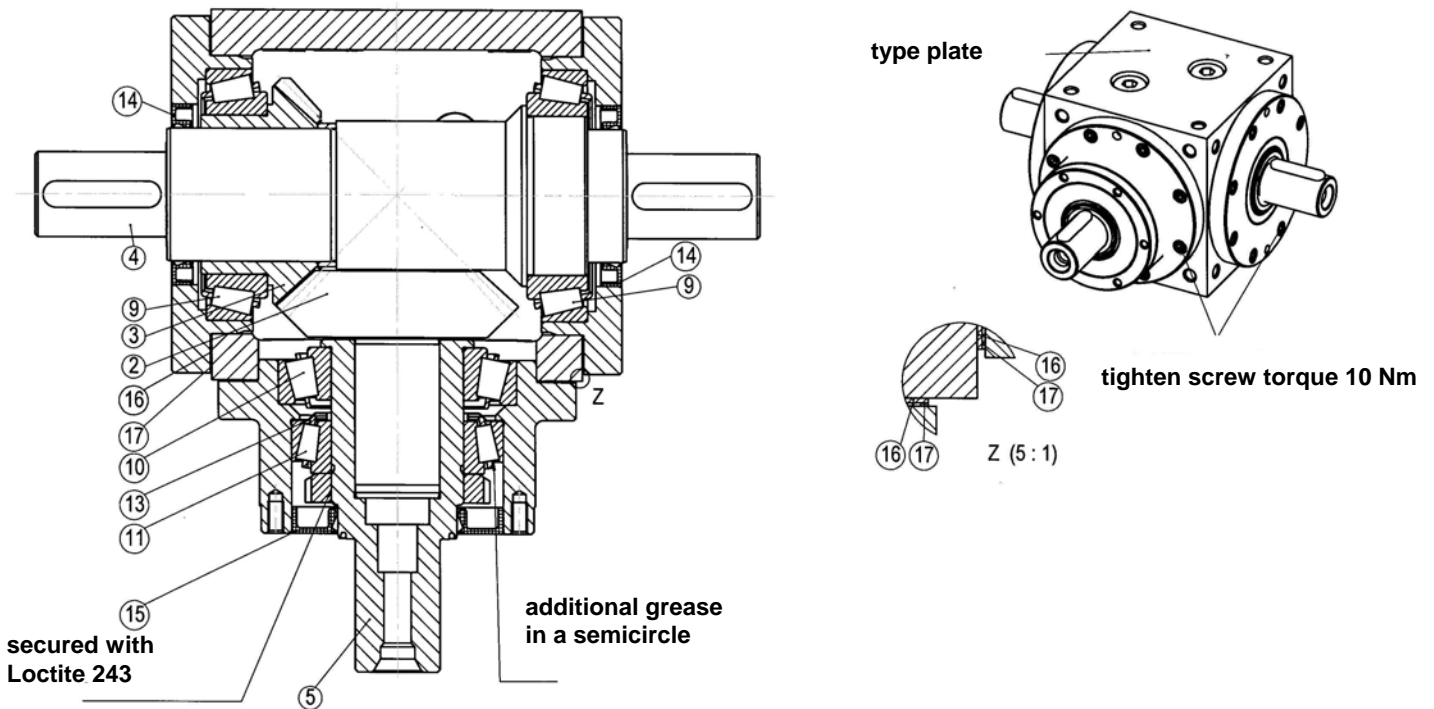

7.2 Parts List

Item	Qty	Description
2	1	Pinion
3	1	Bevel Gear
4	1	Output Shaft
5	1	Input Shaft
9	2	Taper Roller Bearing
10	1	Taper Roller Bearing
11	1	Taper Roller Bearing
13	1	Nilos-Ring
14	2	Shaft Seal
15	1	Shaft Seal
16	3	Sealant Washer
17	3	Shim Set

SPIRAL BEVEL GEARBOXES RANGE “POWERGEAR”

8. Operation

- Prior to initial operation, make sure that all transmission components are correctly installed
- Standard gear layouts do not require a breather/vent filter
- Do not remove, disable or override monitoring and protective devices for trial operation
- Perform initial trials without load and check for abnormal noises and temperature rise

During and after operation, check the surfaces of the PowerGear box housing for abnormal temperature rise

When using mineral gear oils (CLP), the operating temperature should not exceed 90°C and if exceeding it nevertheless, this should only be temporary. When using synthetic gear oils (CLP), an operating temperature of 130°C is admissible.

If abnormal circumstances are encountered (for example, elevated temperatures, noises, vibrations), always shut down the gearbox in case of doubt so that the cause can be ascertained. Contact our Service department if necessary.

9. Initial Operation

Initial operation (assumption of operation in accordance with manufacturer's designated use) of the POWERGEAR gearbox is not permitted until the machine or plant has been validated as compliant with the requirements laid down in the EC Machinery Directive.

10. Inspection and Maintenance

As for life lubrication, the POWERGEAR gearboxes, sizes P75 up to P140 and X75 up to X140, have been provided with synthetic high quality oil on poly-alpha-olefin basis and are thus virtually free from maintenance. Sixes P140 and X140 have been provided with the drill holes needed to make an oil change.

The POWERGEAR gearboxes, sizes P170 up to P280 and X170 up to X280 are delivered without any lubricant filling, except such filling is ordered along with the box.

With operating temperatures to be expected of up to 90°C, we recommend to use mineral gear oil types (CPL) in compliance with standard DIN 51517 or with ISO VG class 100 (DIN 51 519).

For temperatures ranging up to 130°C, we recommend to use synthetic gear oils on poly-alpha-olefin basis (CPL) in compliance with DIN 51517, part 3 or with ISA VG class 150 (DIN 51 519)

SPIRAL BEVEL GEARBOXES RANGE “POWERGEAR”

With mineral oil types, we recommend to make a first oil change after 500 operating hours and after any 5000 operating hours in each case thereafter. When running the gearboxes with synthetic oil types and on continuous duty near to the thermal load limit, we recommend to perform an oil change after any 10, 000 operating hours and, if running them under usual conditions, after 15,000 operating hours in each case.

Oil Volumes (Dependant on gear ratio, rpm, shaft arrangement and installation position)

Construction size	P75/X75	P90/X90	P110/X110	P140/X140	P170/X170	P210/X210	P240/x240	P280/x280
Average oil volume	0.11	0.21	0.31	0.41	1.01	2.21	2.61	3.01
Max. Oil Volume	-	-	0.351	0.61	1.21	2.51	3.51	5.01

Wear part kits including replacement and repair instructions can be obtained from our service department.

SPIRAL BEVEL GEARBOXES RANGE “POWERGEAR”

11. Warranty Information

11.1 Limitation of Responsibility

The ratings given in this manual were compiled using standard engineering procedures. The ratings are designed to guide the customer in the selection of a unit. We do not guarantee the ratings in specific applications. Prototype testing of every application is recommended before production. Our engineering facilities are available for consultation at all times. Please ask us for assistance with linear motion and drive application problems. This manual is designed to assist in the selection of a suitable linear motion or power transmission product for economical, long and trouble free service.

Due to Power Jacks policy of continuous improvement, designs may be subject to change without notice. Please ask for certified drawings.

11.2 Warranty

Subject to the condition stated herein, Power Jacks will repair or replace, without charge, any parts proven to Power Jacks satisfaction to have been defective in material or workmanship. Claims must be made within one year after date of shipment. Power Jacks will not repair or replace any parts that have become inoperative because of improper maintenance, eccentric loading, overloading, chemical or abrasive action, excessive heat, or other abuse. Equipment which has been altered or modified by anyone without Power Jacks authorisation, is not warranted by Power Jacks. EXCEPT AS STATED HEREIN, POWER JACKS MAKES NO OTHER WARRANTIES, EXPRESS OR IMPLIED INCLUDING WARRANTIES OF MERCHANTABILITY AND FITNESS FOR A PARTICULAR PURPOSE.

WARNING: The equipment shown in this manual is intended for industrial use only and should not be used to lift support, or otherwise transport people unless you have a written statement from Power Jacks Limited which authorises the specific unit as used in your application for moving people.

© Power Jacks Limited 1987, Aberdeenshire, Scotland, United Kingdom

We reserve the right to alter details and specifications without notice.

Since special circumstances may affect the equipment’s operation, users should consult **POWER JACKS LIMITED** at the address shown, or take other skilled engineering advice. It is recommended that the application design load is conspicuously displayed.

© **POWER JACKS LIMITED. May not be copied in whole or in part**

POWER JACKS GROUP LIMITED	
SOUTH HARBOUR ROAD, FRASERBURGH, ABERDEENSHIRE AB43 9BZ SCOTLAND	
TELEPHONE: +44 (0) 1346 513131	FAX: +44 (0) 1346 516827
email: sales@powerjacks.com	http://www.powerjacks.com